

WATT

RUBINETTERIE  
**treemme**  
*instruments for water*

 **PADIMAT** DESIGN+  
TECHNIC

# WATT

\_ Design by Studio Q-BIC

“FROM LIGHT TO WATER” THE ARCHITECTURAL FIRM Q-BIC  
SIGNS THE NEW WATT COLLECTION.

WATT IS THE NEW PROPOSAL OF SINGLE-LEVER AND THERMOSTATIC  
SHOWER VALVES FOR BUILT-IN SHOWERS INSPIRED BY  
THE WORLD OF LIGHTING.

“THE ELECTRICITY WORLD WAS PART OF MY FAMILY BACKGROUND,  
AND IT RESURFACED AS I DESIGNED THIS NEW COLLECTION”  
SAID MARCO BALDINI FROM Q-BIC.

“DALLA LUCE ALL’ACQUA” LO STUDIO DI ARCHITETTURA Q-BIC  
FIRMA LA NUOVA COLLEZIONE WATT.

WATT È LA NUOVISSIMA PROPOSTA DI MONOCOMANDO E TERMOSTATICI  
PER DOCCIA DA INCASSO ISPIRATI AL MONDO DELL’ILLUMINAZIONE.

“IL MONDO DELL’ELETTRICITÀ FACEVA PARTE DEL MIO BACKGROUND  
FAMILIARE ED È RIAFFIORATO MENTRE PROGETTAVO QUESTA NUOVA  
COLLEZIONE” RACCONTA MARCO BALDINI DI Q-BIC.

20  
WATT





“I WANTED TO GIVE THIS LINE A VINTAGE LOOK THAT RECALLED  
THE OLD LIGHT SWITCHES, BUT IN A MODERN DESIGN STYLE.  
THE NAME WATT CAME AS A CONSEQUENCE”.

“HO QUINDI VOLUTO DARE A QUESTA LINEA UN ASPETTO VINTAGE CHE  
RICORDASSE LE PLACCHE ELETTRICHE DI UNA VOLTA,  
IL TUTTO OVVIAMENTE IN UN’OTTICA ASSOLUTAMENTE MODERNA E DI  
DESIGN. IL NOME WATT È POI VENUTO DA SÉ DI CONSEGUENZA”.

23  
WATT



24  
KEA



RWIT 2B90 SZ 01 + RWIT 2BF6 SZ 45 + IT RTBR 334 SZ





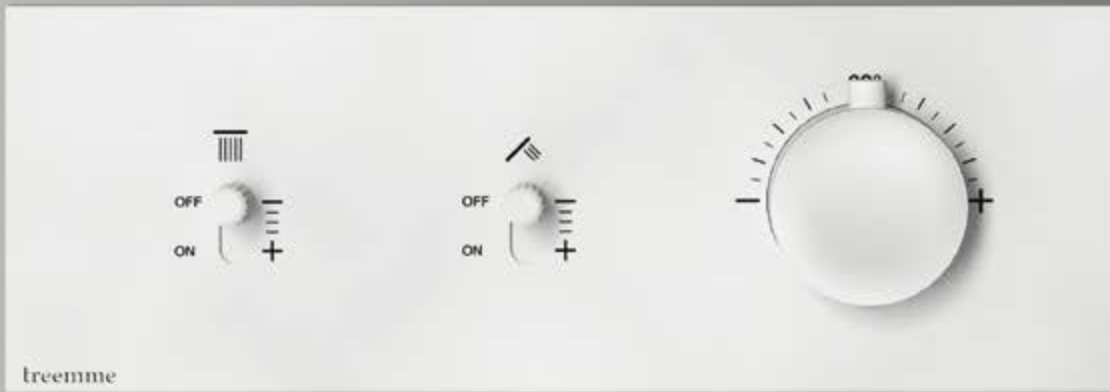

**BB**  
matt white



**NN**  
matt black



**CZ**  
brushed  
black chrome



**HH**  
polished  
black chrome



**NF**  
brushed  
nickel



**SZ**  
brushed  
rose gold



**DZ**  
brushed  
gold



**DD**  
gold 24



**NL**  
polished nickel



**CC**  
chrome





WATT SWITCHES WATER ON AND INSTILLS WELL-BEING,  
IT'S SIMPLE TO USE, WITH A DESIGN STYLE.

29  
WATT

WATT, ACCENDE L'ACQUA E INFONDE BENESSERE,  
GUARDANDO AL DESIGN E ALLA SEMPLICITÀ D'USO.







32  
WATT

WATT IS THE FINAL RESULT OF THE EFFORT, RESEARCH,  
EXPERIMENTATION AND PRODUCTION BY TREEMME,  
THAT HAS CREATED A UNIQUE PRODUCT.

WATT, RISULTATO FINALE DI GRANDE SFORZO DI RICERCA,  
SPERIMENTAZIONE E PRODUZIONE CHE HA IMPEGNATO TREEMME  
NELLA REALIZZAZIONE DI UN PRODOTTO UNICO.









WATT, WITH ITS LINEAR, CLEAN AND TECHNOLOGICAL DESIGN  
CAN ADAPT TO ANY ENVIRONMENT THANKS TO ITS MULTIPLE FINISHES.

35  
WATT

WATT, DESIGN NITIDO, PULITO E TECNOLOGICO,  
PUÒ ADATTARSI A OGNI AMBIENTE GRAZIE ALLE MOLTEPLICI FINITURE.

36  
Q30



IT 2B60 HH WA ZZ



treemme









# Watt

design by Studio Q-BIC

- chrome **CC**
- matt black **NN**
- matt white **BB**
- polished nickel **NL**
- brushed nickel **NF**
- polished black chrome **HH**
- brushed black chrome **CZ**
- gold **DD**
- brushed gold **DZ**
- brushed rose gold **SZ**





CC	RWIT 2B89 CC 01	543,00
NN	RWIT 2B89 NN 01	723,00
BB	RWIT 2B89 BB 01	723,00
NL	RWIT 2B89 NL 01	706,00
NF	RWIT 2B89 NF 01	706,00
HH	RWIT 2B89 HH 01	837,00
CZ	RWIT 2B89 CZ 01	837,00
DD	RWIT 2B89 DD 01	1.130,00
DZ	RWIT 2B89 DZ 01	1.130,00
SZ	RWIT 2B89 SZ 01	1.130,00

Miscelatore monocomando 2 uscite  
2 ways concealed mixer  
Mitigeur à encastrer à 2 sorties  
EHM UP mit 2 Wege

**RWIT 2B89 ZZ 30 339,00**  
+ PARTI INCASSO - CONCEALED BODY  
CORPS À ENCASTRER - UNTERPUTZTEIL

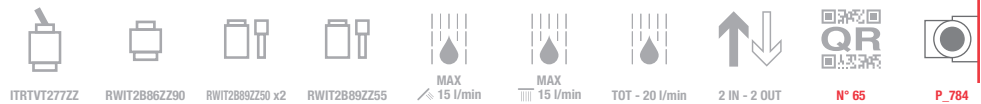
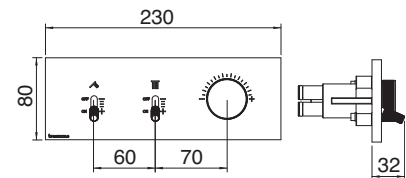

CC	RWIT 2B86 CC 01	588,00
NN	RWIT 2B86 NN 01	783,00
BB	RWIT 2B86 BB 01	783,00
NL	RWIT 2B86 NL 01	765,00
NF	RWIT 2B86 NF 01	765,00
HH	RWIT 2B86 HH 01	906,00
CZ	RWIT 2B86 CZ 01	906,00
DD	RWIT 2B86 DD 01	1.224,00
DZ	RWIT 2B86 DZ 01	1.224,00
SZ	RWIT 2B86 SZ 01	1.224,00

Termostatico incasso 2 uscite  
2 ways concealed thermostatic  
Thermostatique à encastrer à 2 sorties  
UP-Thermostat mit 2 Wege

**RWIT 2B86 ZZ 30 384,00**  
+ PARTI INCASSO - CONCEALED BODY  
CORPS À ENCASTRER - UNTERPUTZTEIL

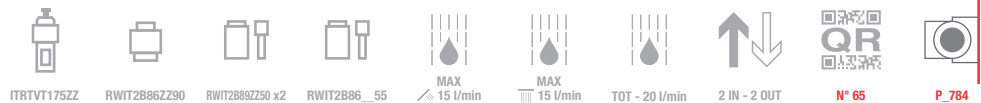
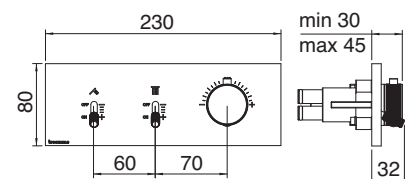

CC	RWIT 2B90 CC 01	633,00
NN	RWIT 2B90 NN 01	842,00
BB	RWIT 2B90 BB 01	842,00
NL	RWIT 2B90 NL 01	823,00
NF	RWIT 2B90 NF 01	823,00
HH	RWIT 2B90 HH 01	975,00
CZ	RWIT 2B90 CZ 01	975,00
DD	RWIT 2B90 DD 01	1.317,00
DZ	RWIT 2B90 DZ 01	1.317,00
SZ	RWIT 2B90 SZ 01	1.317,00

Miscelatore monocomando 3 uscite  
3 ways concealed mixer  
Mitigeur à encastrer à 3 sorties  
EHM UP mit 3 Wege

**RWIT 2B90 ZZ 30 384,00**  
+ PARTI INCASSO - CONCEALED BODY  
CORPS À ENCASTRER - UNTERPUTZTEIL

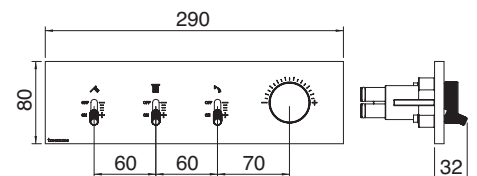

CC	RWIT 2B94 CC 01	678,00
NN	RWIT 2B94 NN 01	902,00
BB	RWIT 2B94 BB 01	902,00
NL	RWIT 2B94 NL 01	882,00
NF	RWIT 2B94 NF 01	882,00
HH	RWIT 2B94 HH 01	1.045,00
CZ	RWIT 2B94 CZ 01	1.045,00
DD	RWIT 2B94 DD 01	1.411,00
DZ	RWIT 2B94 DZ 01	1.411,00
SZ	RWIT 2B94 SZ 01	1.411,00

Termostatico incasso 3 uscite  
3 ways concealed thermostatic  
Thermostatique à encastrer avec 3 sorties  
UP-Thermostat mit 3 Wege

**RWIT 2B94 ZZ 30 430,00**  
+ PARTI INCASSO - CONCEALED BODY  
CORPS À ENCASTRER - UNTERPUTZTEIL

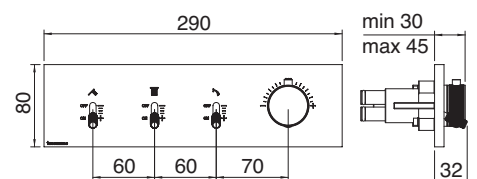







treemse







CC	RWIT 2BE4 CC 01	769,00
NN	RWIT 2BE4 NN 01	1.023,00
BB	RWIT 2BE4 BB 01	1.023,00
NL	RWIT 2BE4 NL 01	1.000,00
NF	RWIT 2BE4 NF 01	1.000,00
HH	RWIT 2BE4 HH 01	1.185,00
CZ	RWIT 2BE4 CZ 01	1.185,00
DD	RWIT 2BE4 DD 01	1.600,00
DZ	RWIT 2BE4 DZ 01	1.600,00
SZ	RWIT 2BE4 SZ 01	1.600,00

Miscelatore monocomando 4 uscite  
4 ways concealed mixer  
Mitigeur à encastrer à 4 sorties  
EHM UP mit 4 Wege

**RWIT 2BE4 ZZ 30 475,00**  
+ PARTI INCASSO - CONCEALED BODY  
CORPS À ENCASTREUR - UNTERPUTZTEIL

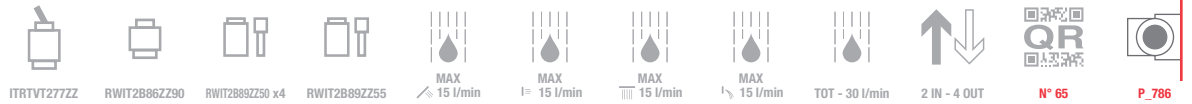
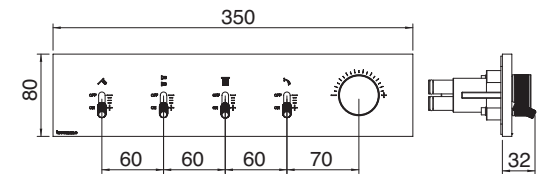

CC	RWIT 2BF4 CC 01	814,00
NN	RWIT 2BF4 NN 01	1.083,00
BB	RWIT 2BF4 BB 01	1.083,00
NL	RWIT 2BF4 NL 01	1.059,00
NF	RWIT 2BF4 NF 01	1.059,00
HH	RWIT 2BF4 HH 01	1.254,00
CZ	RWIT 2BF4 CZ 01	1.254,00
DD	RWIT 2BF4 DD 01	1.694,00
DZ	RWIT 2BF4 DZ 01	1.694,00
SZ	RWIT 2BF4 SZ 01	1.694,00

Termostatico incasso 4 uscite  
4 ways concealed thermostatic  
Thermostatique à encastrer avec 4 sorties  
UP-Thermostat mit 4 Wege

**RWIT 2BF4 ZZ 30 520,00**  
+ PARTI INCASSO - CONCEALED BODY  
CORPS À ENCASTREUR - UNTERPUTZTEIL

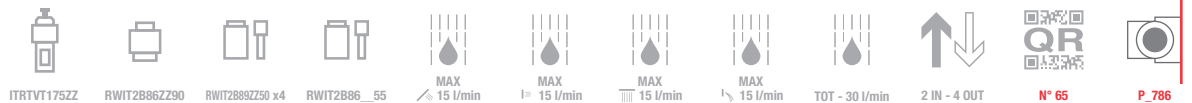
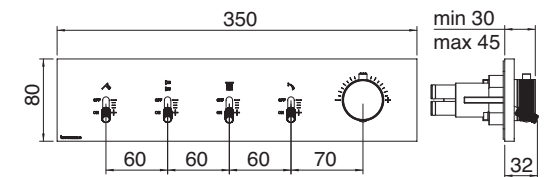

CC	RWIT 2BE5 CC 01	859,00
NN	RWIT 2BE5 NN 01	1.143,00
BB	RWIT 2BE5 BB 01	1.143,00
NL	RWIT 2BE5 NL 01	1.117,00
NF	RWIT 2BE5 NF 01	1.117,00
HH	RWIT 2BE5 HH 01	1.323,00
CZ	RWIT 2BE5 CZ 01	1.323,00
DD	RWIT 2BE5 DD 01	1.787,00
DZ	RWIT 2BE5 DZ 01	1.787,00
SZ	RWIT 2BE5 SZ 01	1.787,00

Miscelatore monocomando 5 uscite  
5 ways concealed mixer  
Mitigeur à encastrer à 5 sorties  
EHM UP mit 5 Wege

**RWIT 2BE5 ZZ 30 520,00**  
+ PARTI INCASSO - CONCEALED BODY  
CORPS À ENCASTREUR - UNTERPUTZTEIL

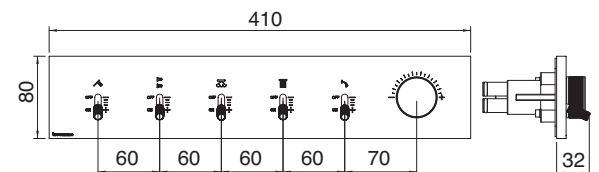

CC	RWIT 2BF5 CC 01	904,00
NN	RWIT 2BF5 NN 01	1.203,00
BB	RWIT 2BF5 BB 01	1.203,00
NL	RWIT 2BF5 NL 01	1.176,00
NF	RWIT 2BF5 NF 01	1.176,00
HH	RWIT 2BF5 HH 01	1.393,00
CZ	RWIT 2BF5 CZ 01	1.393,00
DD	RWIT 2BF5 DD 01	1.881,00
DZ	RWIT 2BF5 DZ 01	1.881,00
SZ	RWIT 2BF5 SZ 01	1.881,00

Termostatico incasso 5 uscite  
5 ways concealed thermostatic  
Thermostatique à encastrer avec 5 sorties  
UP-Thermostat mit 5 Wege

**RWIT 2BF5 ZZ 30 565,00**  
+ PARTI INCASSO - CONCEALED BODY  
CORPS À ENCASTREUR - UNTERPUTZTEIL

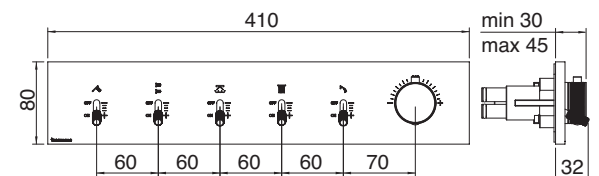



CC	RWIT 2B91 CC 01	814,00
NN	RWIT 2B91 NN 01	1.083,00
BB	RWIT 2B91 BB 01	1.083,00
NL	RWIT 2B91 NL 01	1.059,00
NF	RWIT 2B91 NF 01	1.059,00
HH	RWIT 2B91 HH 01	1.254,00
CZ	RWIT 2B91 CZ 01	1.254,00
DD	RWIT 2B91 DD 01	1.694,00
DZ	RWIT 2B91 DZ 01	1.694,00
SZ	RWIT 2B91 SZ 01	1.694,00

Miscelatore monocomando 2 uscite  
2 ways concealed mixer  
Mitigeur à encastrer à 2 sorties  
EHM UP mit 2 Wege

**RWIT 2B91 ZZ 30 384,00**  
+ PARTI INCASSO - CONCEALED BODY  
CORPS À ENCASTRER - UNTERPUTZTEIL

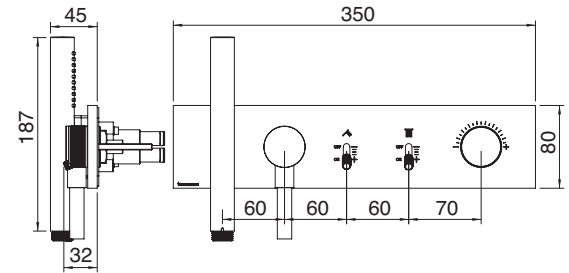

ITRTVT27ZZ RWIT2B86ZZ90 RWIT2B89ZZ50 x2 RWIT2B89ZZ55 1,5 M PVC METAL 8 l/min MAX 15 l/min TOT - 20 l/min 2 IN - 1 OUT N° 65 P\_784



CC	RWIT 2B92 CC 01	859,00
NN	RWIT 2B92 NN 01	1.143,00
BB	RWIT 2B92 BB 01	1.143,00
NL	RWIT 2B92 NL 01	1.117,00
NF	RWIT 2B92 NF 01	1.117,00
HH	RWIT 2B92 HH 01	1.323,00
CZ	RWIT 2B92 CZ 01	1.323,00
DD	RWIT 2B92 DD 01	1.787,00
DZ	RWIT 2B92 DZ 01	1.787,00
SZ	RWIT 2B92 SZ 01	1.787,00

Termostatico incasso 2 uscite  
2 ways concealed thermostatic  
Thermostatique à encastrer avec 2 sorties  
UP-Thermostat mit 2 Wege

**RWIT 2B92 ZZ 30 430,00**  
+ PARTI INCASSO - CONCEALED BODY  
CORPS À ENCASTRER - UNTERPUTZTEIL

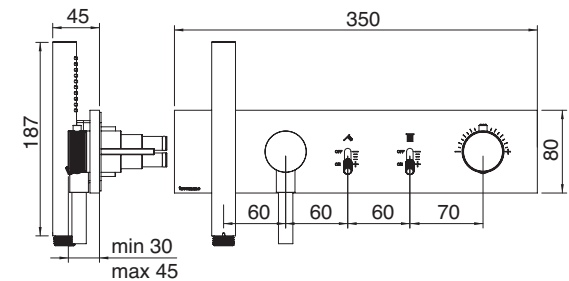

ITRTVT175ZZ RWIT2B86ZZ90 RWIT2B89ZZ50 x2 RWIT2B86\_55 1,5 M PVC METAL 8 l/min MAX 15 l/min TOT - 20 l/min 2 IN - 1 OUT N° 65 P\_785



CC	RWIT 2B97 CC 01	950,00
NN	RWIT 2B97 NN 01	1.264,00
BB	RWIT 2B97 BB 01	1.264,00
NL	RWIT 2B97 NL 01	1.235,00
NF	RWIT 2B97 NF 01	1.235,00
HH	RWIT 2B97 HH 01	1.463,00
CZ	RWIT 2B97 CZ 01	1.463,00
DD	RWIT 2B97 DD 01	1.976,00
DZ	RWIT 2B97 DZ 01	1.976,00
SZ	RWIT 2B97 SZ 01	1.976,00

Miscelatore monocomando 3 uscite  
3 ways concealed mixer  
Mitigeur à encastrer à 3 sorties  
EHM UP mit 3 Wege

**RWIT 2B97 ZZ 30 475,00**  
+ PARTI INCASSO - CONCEALED BODY  
CORPS À ENCASTRER - UNTERPUTZTEIL

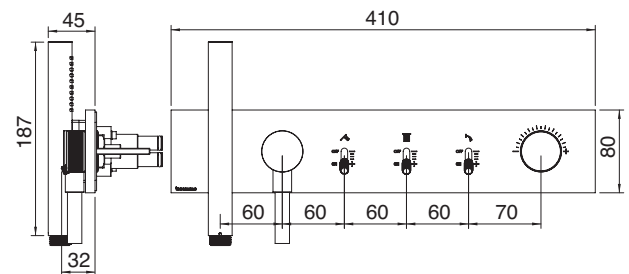

ITRTVT27ZZ RWIT2B86ZZ90 RWIT2B89ZZ50 x3 RWIT2B89ZZ55 1,5 M PVC METAL 8 l/min MAX 15 l/min MAX 15 l/min TOT - 25 l/min 2 IN - 2 OUT N° 65 P\_785



CC	RWIT 2B98 CC 01	995,00
NN	RWIT 2B98 NN 01	1.324,00
BB	RWIT 2B98 BB 01	1.324,00
NL	RWIT 2B98 NL 01	1.294,00
NF	RWIT 2B98 NF 01	1.294,00
HH	RWIT 2B98 HH 01	1.533,00
CZ	RWIT 2B98 CZ 01	1.533,00
DD	RWIT 2B98 DD 01	2.070,00
DZ	RWIT 2B98 DZ 01	2.070,00
SZ	RWIT 2B98 SZ 01	2.070,00

Termostatico incasso 3 uscite  
3 ways concealed thermostatic  
Thermostatique à encastrer avec 3 sorties  
UP-Thermostat mit 3 Wege

**RWIT 2B98 ZZ 30 520,00**  
+ PARTI INCASSO - CONCEALED BODY  
CORPS À ENCASTRER - UNTERPUTZTEIL

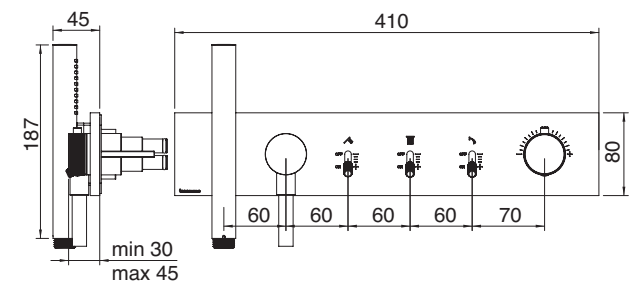

ITRTVT175ZZ RWIT2B86ZZ90 RWIT2B89ZZ50 x3 RWIT2B86\_55 1,5 M PVC METAL 8 l/min MAX 15 l/min MAX 15 l/min TOT - 25 l/min 2 IN - 2 OUT N° 65 P\_785



**BB**  
matt white



**NN**  
matt black



**CZ**  
brushed  
black chrome



**HH**  
polished  
black chrome



**NF**  
brushed  
nickel



**SZ**  
brushed  
rose gold



**DZ**  
brushed  
gold



**DD**  
gold



**NL**  
polished nickel



**CC**  
chrome





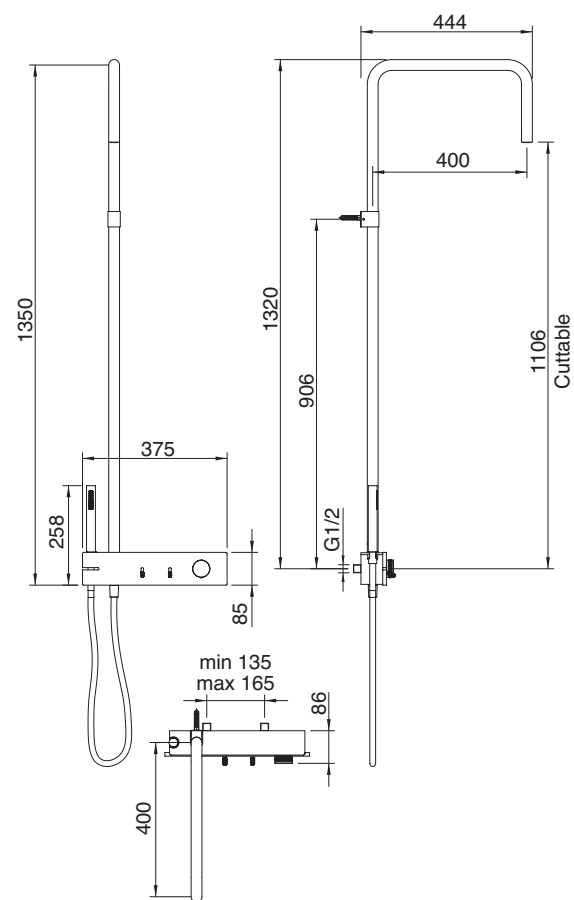

CC	IT 2B60 CC WA ZZ	1.492,00
NN	IT 2B60 NN WA ZZ	1.985,00
BB	IT 2B60 BB WA ZZ	1.985,00
NL	IT 2B60 NL WA ZZ	1.940,00
NF	IT 2B60 NF WA ZZ	1.940,00
HH	IT 2B60 HH WA ZZ	2.298,00
CZ	IT 2B60 CZ WA ZZ	2.298,00
DD	IT 2B60 DD WA ZZ	3.104,00
DZ	IT 2B60 DZ WA ZZ	3.104,00
SZ	IT 2B60 SZ WA ZZ	3.104,00

Gruppo doccia con doccetta e soffione  
 Wall-mtd. shower set, hand-shower and shower head  
 Mitigeur douche mural, douchette et tête de douche  
 Regenbrause-Set, Handbrause und Kopfbrause



 ITRTV1280ZZ  
 RWIT2B86ZZ90  
 9 l/min ITRTAE180ZZ  
 8 l/min  
 QR N° 66  
 P\_642



CC	RWIT 2BF6 CC 25	317,00
NN	RWIT 2BF6 NN 25	422,00
BB	RWIT 2BF6 BB 25	422,00
NL	RWIT 2BF6 NL 25	413,00
NF	RWIT 2BF6 NF 25	413,00
HH	RWIT 2BF6 HH 25	489,00
CZ	RWIT 2BF6 CZ 25	489,00
DD	RWIT 2BF6 DD 25	660,00
DZ	RWIT 2BF6 DZ 25	660,00
SZ	RWIT 2BF6 SZ 25	660,00

**RWIT 2BF6 ZZ 40 68,00**  
 +  PARTI INCASSO - CONCEALED BODY  
 CORPS À ENCASTRER - UNTERPUTZTEIL

Kit gancio, flessibile, doccetta attacco a calamita  
 Hook, flexible and hand shower with magnet fixing  
 Kit support, flexible et douchette à fixation magnétique  
 Brausehalter, Schlauch und Handbrause mit Magnetbefestigung

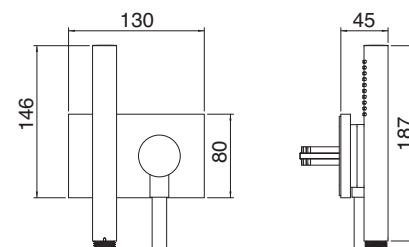

1,5 M PVC



METAL



1/2 M



1/2 M



8 l/min



N° 65



P\_787



CC	RWIT 2BF6 CC 45	362,00
NN	RWIT 2BF6 NN 45	482,00
BB	RWIT 2BF6 BB 45	482,00
NL	RWIT 2BF6 NL 45	471,00
NF	RWIT 2BF6 NF 45	471,00
HH	RWIT 2BF6 HH 45	558,00
CZ	RWIT 2BF6 CZ 45	558,00
DD	RWIT 2BF6 DD 45	753,00
DZ	RWIT 2BF6 DZ 45	753,00
SZ	RWIT 2BF6 SZ 45	753,00

**RWIT 2BF6 ZZ 40 68,00**  
 +  PARTI INCASSO - CONCEALED BODY  
 CORPS À ENCASTRER - UNTERPUTZTEIL

Kit gancio, flessibile, doccetta attacco a calamita  
 Hook, flexible and hand shower with magnet fixing  
 Kit support, flexible et douchette à fixation magnétique  
 Brausehalter, Schlauch und Handbrause mit Magnetbefestigung

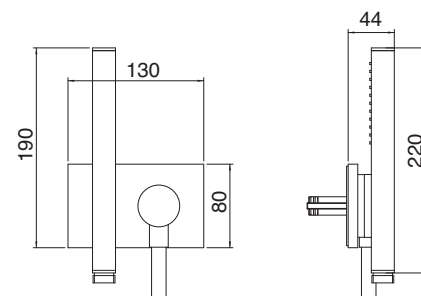

1,5 M PVC



METAL



1/2 M



1/2 M



8 l/min



N° 65



P\_787



CC	IT RTFL 523 CC	30,00
NN	IT RTFL 523 NN	40,00
BB	IT RTFL 523 BB	40,00
NL	IT RTFL 523 NL	39,00
NF	IT RTFL 523 NF	39,00
HH	IT RTFL 523 HH	47,00
CZ	IT RTFL 523 CZ	47,00
DD	IT RTFL 523 DD	63,00
DZ	IT RTFL 523 DZ	63,00
SZ	IT RTFL 523 SZ	63,00

Flessibile m. 1,5 PVC - WATT  
 WATT - PVC 1,5 m. flexible hose  
 Flexible m. 1,5 en PVC - WATT  
 Brauseschlauch m 1,5 PVC - WATT

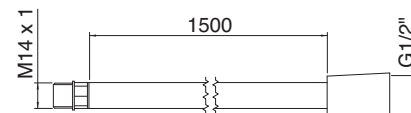

1,5 M PVC

Per ulteriori composizioni doccia vedi sezione SHOWERS & THERMOSTATICS

For other shower fittings check the SHOWERS & THERMOSTATICS section

Pour d'autres solutions douche voir section SHOWERS & THERMOSTATICS

Für weitere duschaustattungen siehe abschnitt SHOWERS & THERMOSTATICS





# Watt \_ Concealed bodies



**ZZ RWIT 2B86 ZZ 30 384,00**

Termostatico incasso 2 uscite - Parti incasso  
2 ways concealed thermostatic - Concealed body  
Thermostatique à encastrer avec 2  
sorties - Corps à encastrer  
UP-Thermostat mit 2 Wege - Unterputzteil

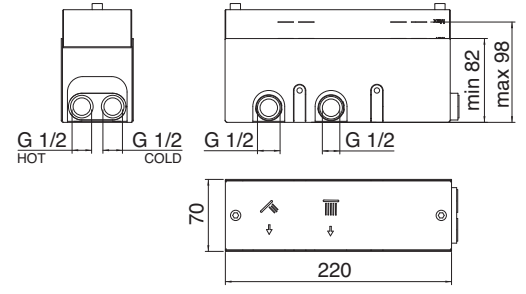

**ZZ RWIT 2B89 ZZ 30 339,00**

Miscelatore monocomando 2 uscite - Parti incasso  
2 ways concealed mixer - Concealed body  
Mitigeur à encastrer à 2 sorties - Corps à encastrer  
EHM UP mit 2 Wege - Unterputzteil

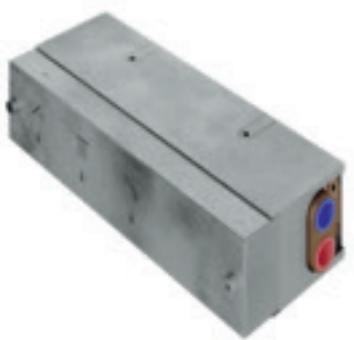
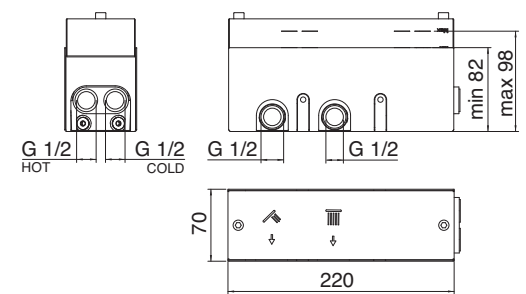

**ZZ RWIT 2B90 ZZ 30 384,00**

Miscelatore monocomando 3 uscite - Parti incasso  
3 ways concealed mixer - Concealed body  
Mitigeur à encastrer à 3 sorties - Corps à encastrer  
EHM UP mit 3 Wege - Unterputzteil

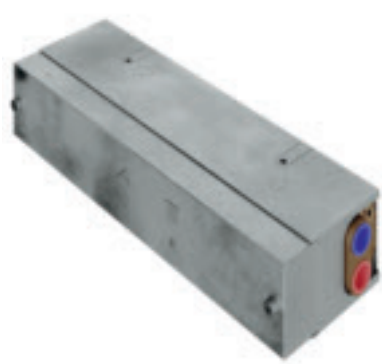
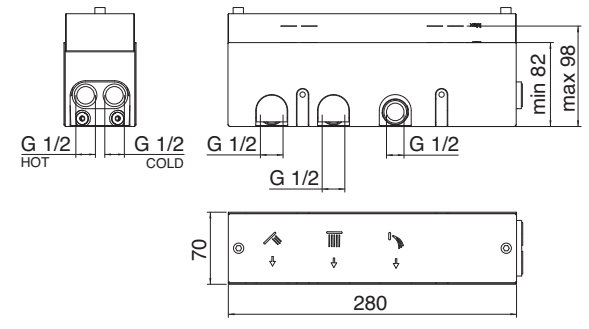

**ZZ RWIT 2B91 ZZ 30 384,00**

Miscelatore monocomando 2 uscite - Parti incasso  
2 ways concealed mixer - Concealed body  
Mitigeur à encastrer à 2 sorties - Corps à encastrer  
EHM UP mit 2 Wege - Unterputzteil

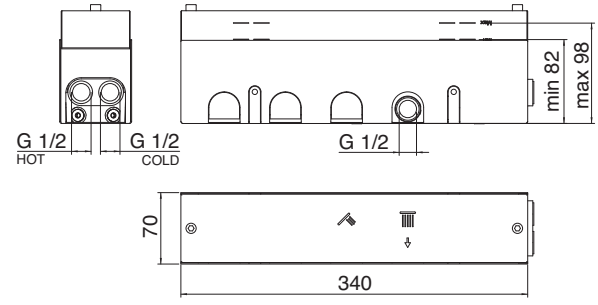

# Watt \_ Concealed bodies

**ZZ RWIT 2B92 ZZ 30 430,00**

Termostatico incasso 2 uscite - Parti incasso  
 2 ways concealed thermostat - Concealed body  
 Thermostatique à encastrer avec 2 sorties - Corps à encastrer  
 UP-Thermostat mit 2 Wege - Unterputzteil



INCLUDING N° 65

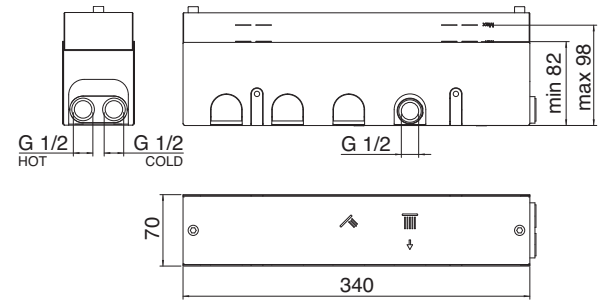

**ZZ RWIT 2B94 ZZ 30 430,00**

Termostatico incasso 3 uscite - Parti incasso  
 3 ways concealed thermostat - Concealed body  
 Thermostatique à encastrer avec 3 sorties - Corps à encastrer  
 UP-Thermostat mit 3 Wege - Unterputzteil

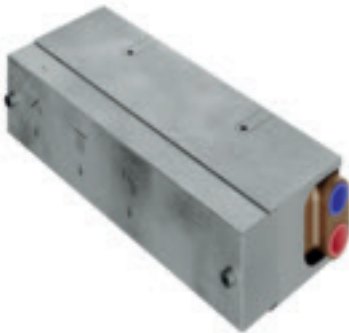

INCLUDING N° 65

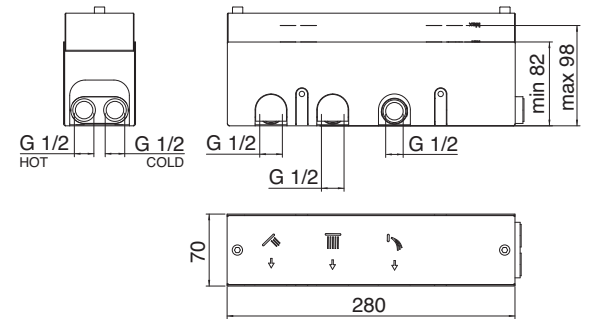

**ZZ RWIT 2B97 ZZ 30 475,00**

Miscelatore monocomando 3 uscite - Parti incasso  
 3 ways concealed mixer - Concealed body  
 Mitigeur à encastrer à 3 sorties - Corps à encastrer  
 EHM UP mit 3 Wege - Unterputzteil



INCLUDING N° 65

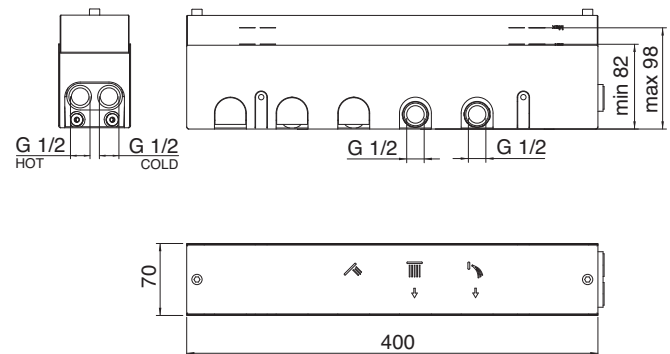

**ZZ RWIT 2B98 ZZ 30 520,00**

Termostatico incasso 3 uscite - Parti incasso  
 3 ways concealed thermostat - Concealed body  
 Thermostatique à encastrer avec 3 sorties - Corps à encastrer  
 UP-Thermostat mit 3 Wege - Unterputzteil



INCLUDING N° 65

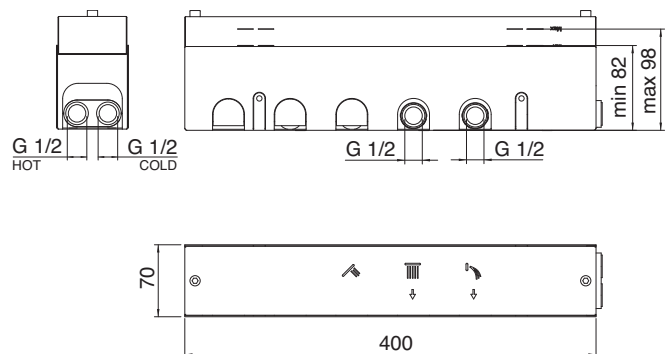

X-CHANGE

ELECTRONIC

SHOWERS & THERMOSTATICS

PICCADILLY

OLD ITALY

NUOVA RETRÒ

ROMANTICA

CONCEALED PARTS - ACCESSORIES

# Watt \_ Concealed bodies

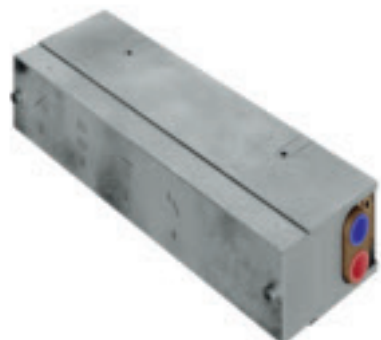

**ZZ RWIT 2BE4 ZZ 30 475,00**

Miscelatore monocomando 4 uscite - Parti incasso  
 4 ways concealed mixer - Concealed body  
 Mitigeur à encastrer à 4 sorties - Corps à encastrer  
 EHM UP mit 4 Wege - Unterputzteil

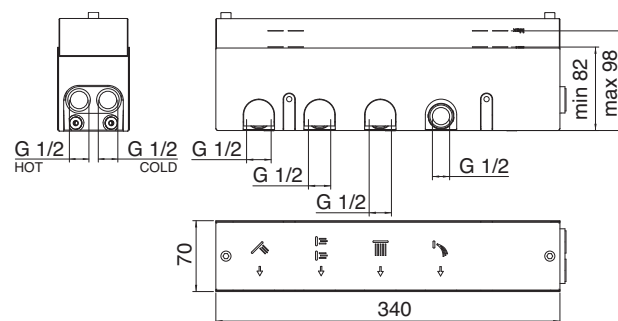

**ZZ RWIT 2BE5 ZZ 30 520,00**

Miscelatore monocomando 5 uscite - Parti incasso  
 5 ways concealed mixer - Concealed body  
 Mitigeur à encastrer à 5 sorties - Corps à encastrer  
 EHM UP mit 5 Wege - Unterputzteil

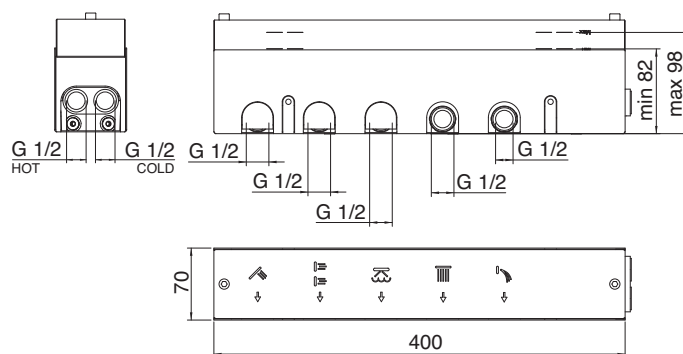

**ZZ RWIT 2BF4 ZZ 30 520,00**

Termostatico incasso 4 uscite - Parti incasso  
 4 ways concealed thermostatic - Concealed body  
 Thermostatique à encastrer avec 4 sorties - Corps à encastrer  
 UP-Thermostat mit 4 Wege - Unterputzteil

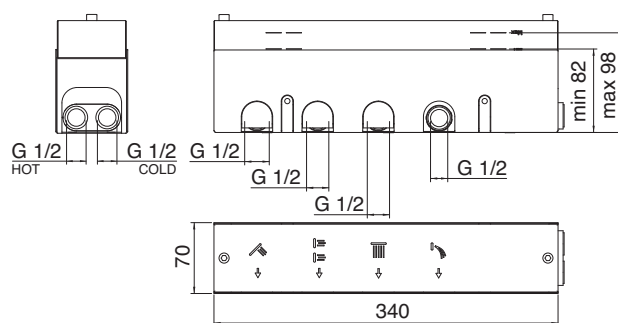

**ZZ RWIT 2BF5 ZZ 30 565,00**

Termostatico incasso 5 uscite - Parti incasso  
 5 ways concealed thermostatic - Concealed body  
 Thermostatique à encastrer avec 5 sorties - Corps à encastrer  
 UP-Thermostat mit 5 Wege - Unterputzteil

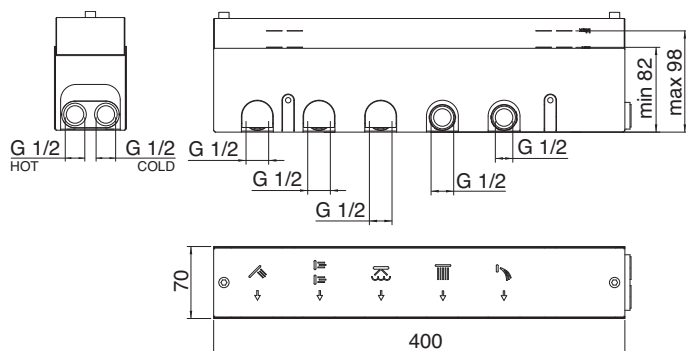



# Watt \_ Concealed bodies

**ZZ RWIT 2BF6 ZZ 40 68,00**

Kit gancio, flessibile, doccia - Parti incasso  
Hook, flexible and hand shower kit - Concealed body  
Kit support, flexible et douche - Corps à encastrer  
Brausehalter, Schlauch und Handbrause - Unterputzteil

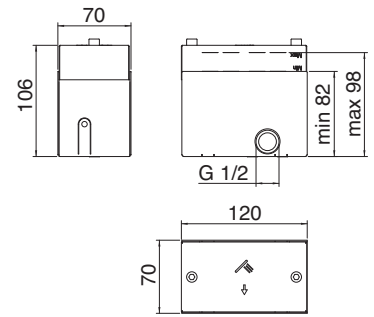

INCLUDING

N° 65

# Cartridges - Valves

**ZZ RWIT 2B86 ZZ 90 25,00**

Cartuccia E26 - per leve serie Watt  
E26 Cartridge - for WATT series levers  
Cartouche E26 - pour leviers serie WATT  
Kartusche E26 - für Hebel Watt Serie



# Pulizia e manutenzione - Cleaning/maintenance

## COSA FARE

Per una perfetta cura del vostro rubinetto è opportuno asciugare con un panno morbido i rubinetti dopo ogni utilizzo al fine di evitare che gocce di acqua lascino sulle superfici depositi di calcare difficili da rimuovere.

## RUBINETTERIA CROMATA

In presenza di calcare o di aloni si consiglia l'uso di prodotti naturali, preservando quindi anche l'ambiente. Utilizzare un panno di cotone morbido con aceto bianco 1 parte da diluire sempre con 3 parti d'acqua

In alternativa è possibile utilizzare detergenti delicati a base di acido citrico

Ricordarsi di risciacquare con acqua e di asciugare alla perfezione

## RUBINETTERIA IN FINITURA

Le rubinetterie con finiture colorate vanno pulite esclusivamente con un panno e acqua corrente o con un detergente estremamente delicato a PH neutro (7). Detergenti contenenti abrasivi o alcool, cosiddetti decalcificatori, sono infatti nemici dei rubinetti colorati

## IMPORTANTE

Ridurre al minimo l'utilizzo di detergenti

## COSA NON FARE

Non utilizzare detergenti a base di sostanze acide e fortemente corrosive (acido acetico, amminoacidi, idrossido di sodio e ipoclorito di sodio, acido fosforico, acido salino). Evitare spugne abrasive o paglie ruvide metalliche, panni in microfibra che potrebbero rovinare irreparabilmente la superficie

---

## WHAT TO DO

Take perfect care of your tap by drying it with a soft cloth after each use so as to prevent drops of water from leaving deposits of limescale on the surfaces, which are difficult to remove.

## CHROME TAPS

It is advisable to use natural products for limescale or streaks so as to also protect the environment. Use a soft cotton cloth with 1 part white vinegar diluted with 3 parts water

Alternatively, mild citric acid based detergent can be used

Remember to rinse with water and dry perfectly

## TAPS WITH FINISH

Taps with a coloured finish must only be cleaned with a cloth and running water or with an extremely mild detergent with neutral PH (7). Detergents containing abrasives or alcohol, so-called descalers, are in fact enemies of coloured taps

## IMPORTANT NOTE

Use detergents as least as possible

## WHAT NOT TO DO

Do not use detergents containing acidic and highly corrosive substances (acetic acid, amino acids, sodium hydroxide and sodium hypochlorite, phosphoric acid, saline acid). Avoid abrasive sponges or rough metal scouring pads or microfibre cloths that could irreparably ruin the surface

## QUOI FAIRE

Essuyez avec un chiffon doux et propre après chaque utilisation

## ROBINETTERIE CHROMÉE

Les résidus de calcaire se forment surtout dans les angles et dans les jonctions. Pour les éliminer, nous vous conseillons un nettoyant délicat à base d'acide citrique. Ne pas le pulvériser directement sur la zone concernée mais sur un chiffon. En cas de taches de calcaire ou de halos, nettoyez la surface avec du vinaigre dilué avec de l'eau (1/3 de vinaigre, 2/3 d'eau) Rincez abondamment et essuyez avec un chiffon doux et propre après chaque utilisation

## ROBINETS AVEC DES FINITIONS AUTRES QUE LE CHROME

Les robinets avec des finitions autres que le chrome doivent être nettoyés avec un chiffon doux et propre à l'eau tiède ou avec nettoyant très délicat au pH neutre (7). Évitez d'utiliser des produits de nettoyage contenant des substances abrasives et/ou à base de chlore comme l'eau de javel, l'acide chlorhydrique (muriatique), les détartrants, etc.

## IMPORTANT

Réduire l'utilisation de détergents

## CE QU'IL NE FAUT PAS FAIRE

Évitez d'utiliser des produits de nettoyage contenant des substances abrasives et/ou à base de chlore comme l'eau de javel, l'acide chlorhydrique (muriatique), acide acétique, acides aminés, hydroxyde de sodium et hypochlorite de sodium, acide phosphorique, acide salin), les détartrants, etc.

Ne pas utiliser d'outils contenant du fer, tels que les paillettes à récurer, les brosses ou les grattoirs en acier.

Ne pas utiliser les mousses abrasives, les brosses ou les chiffons microfibre

---

## VORGEHENSWEISE

Für eine perfekte Pflege Ihrer Armaturen ist es ratsam, die Hähne nach jedem Gebrauch mit einem weichen Lappen zu trocknen, um zu vermeiden, dass Wassertropfen Kalkrückstände an den Oberflächen hinterlassen, die nicht leicht zu entfernen sind.

## VERCHROMTE ARMATUREN

Wenn Kalkrückstände oder -ränder vorhanden sind, ist es ratsam, natürliche Produkte zu verwenden, um dadurch auch die Umwelt zu schützen. Einen weichen Baumwolllappen mit weißem Essig verwenden, wobei 1 Teil Essig mit 3 Teilen Wasser verdünnt wird

Als Alternative können auch milde Reinigungsmittel auf Zitronensäurebasis verwendet werden

Nicht vergessen, mit Wasser abzuspülen und perfekt zu trocknen

## ARMATUREN MIT FARBIGEM FINISH

Armaturen mit farbigem Finish dürfen nur mit einem Lappen und fließendem Wasser oder mit einem sehr milden Reinigungsmittel mit neutralen PH (7) gereinigt werden. Reinigungsmittel, die scheuernde Partikel oder Alkohol enthalten, also sogenannte Kalklösungsmittel, sind für farbige Armaturen sehr schädlich

## WICHTIG

Den Gebrauch von Reinigungsmitteln auf ein Minimum reduzieren

## VERMEIDEN

Keine Reinigungsmittel auf Basis von sauren und stark ätzenden Stoffen (Essigsäure, Aminosäuren, Natriumhydroxid und Natriumhypochlorit, Phosphorsäure, Salzsäure) verwenden. Keine Scheuerschwämme, rauen Topfreiniger aus Metall oder Mikrofasertücher benutzen, durch die die Armaturenoberfläche dauerhaft beschädigt werden könnte



I dati e le immagini contenuti nel presente catalogo sono da ritenersi indicativi,  
Rubinetterie 3M S.r.l. si riserva la facoltà di modificare o adeguare anche senza obbligo di preavviso

The images and information contained in this catalogue are to be considered indicative  
and may be subject to variations without prior notice

Les images et les informations contenues dans ce catalogue sont fournies à titre indicatif  
et peuvent faire l'objet de modifications sans aucun préavis

Die in diesem Katalog enthaltenen Bilder und Daten dienen nur zur Illustration  
und können auch ohne vorherige Ankündigung geändert werden

Изображения и данные, содержащиеся в этом каталоге, следует рассматривать как ориентировочные  
и могут быть изменены даже без предварительного уведомления

Las imágenes y datos que apare en este catálogo son a modo indicativo pudiendo  
sufrir variaciones incluso sin previo aviso

本图册中包含的皆为指示性的图片与信息  
如有更改，恕不另行通知

**treemme** RUBINETTERIE  
*instruments for water*

**PADIMAT** DESIGN+  
TECHNIC

SHOP | **OFFLINE**

..  
SHOWROOM

SHOP | **ONLINE**

..  
PADIMAT.PT

..  
**OFFICE**

Rua José Martins Maia, 45  
4486-854 Vilar do Pinheiro  
+351 220 028 270

..  
**SHOWROOM**

Via Norte Trade Center  
Estrada Nacional 13, 122  
4470-177 Maia  
+351 220 028 280

..  
**WAREHOUSE**

ABP - Azevedo's Business Park  
Rua da Indústria, 150  
4485-946 Vilar do Pinheiro  
+351 220 028 286